

Built-in PIN Photodiode Characteristics

Fig. 95-1 Photodiode Frequency Response Characteristic

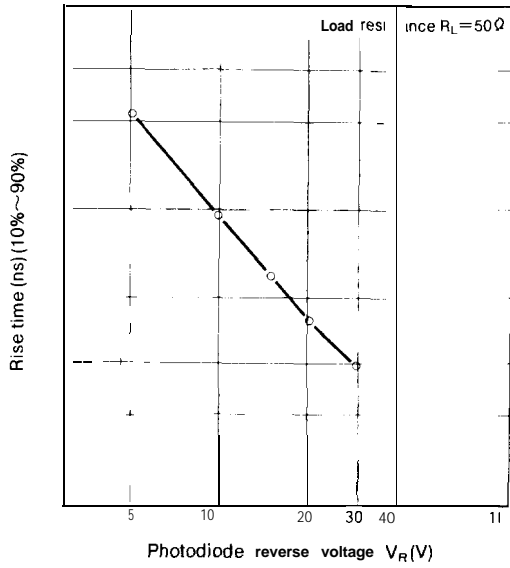
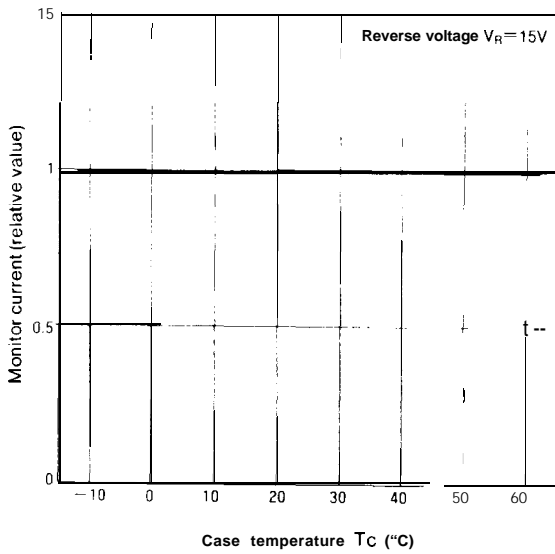

Fig. 95-2 Photodiode Temperature Characteristic



Note All data on this page is typical only, and is not intended as a specification. The shapes of these curves can be used as a general reference, but the actual characteristics will vary from device to device.

Outline Dimensions

Unit mm

Fig. 98-1 Standard Type (C Type)

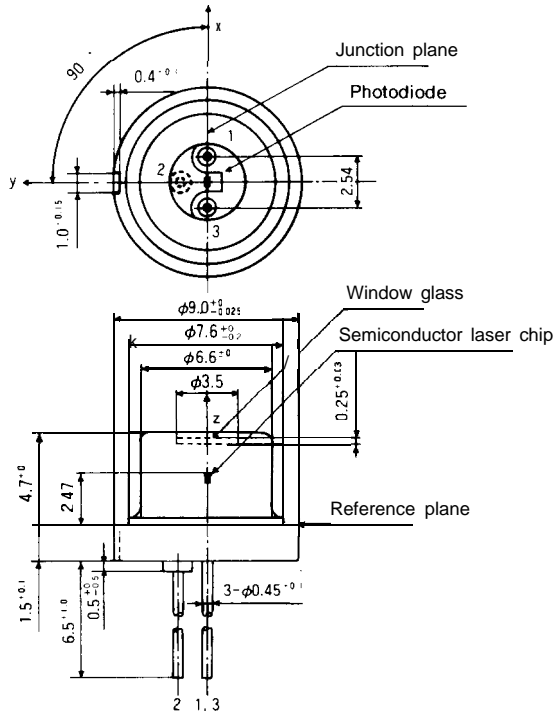

Fig. 982 Low-Cap Type (D Type)

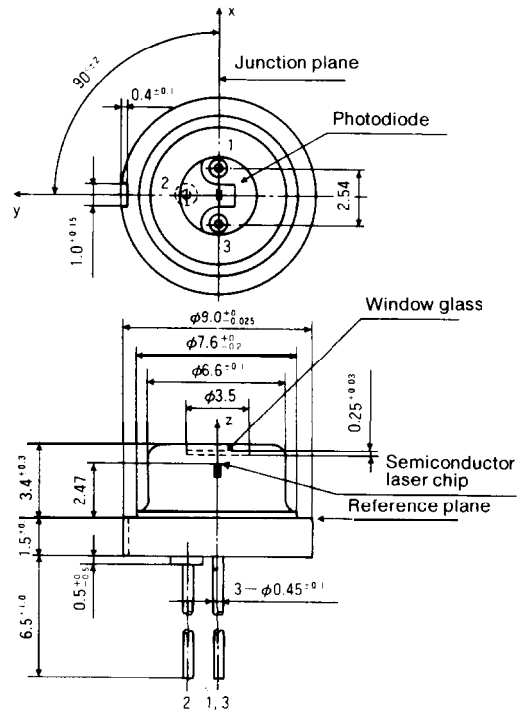

Fig. 98-3 Fin-Equipped Type (F Type)

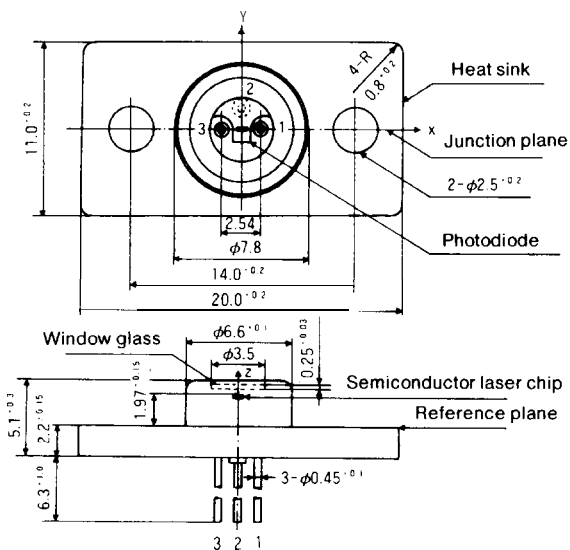
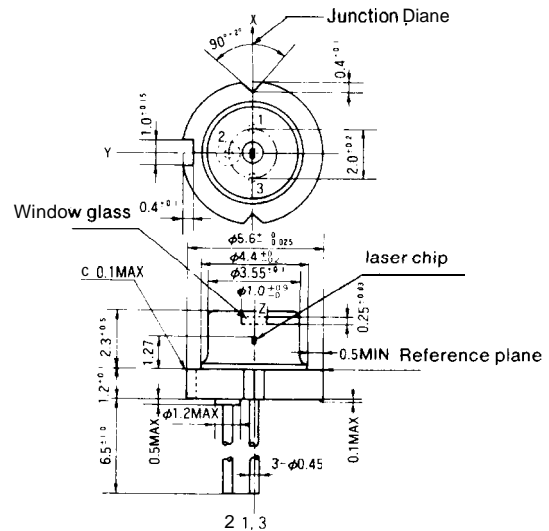

Fig. 98-4 Compact Package Type (S Type)



Terminal connections

